

Differential Pressure Gauge Filter clog Indicator

DIFFERENTIAL PRESSURE MONITORING :
Differential Pressure Instrument measures the difference in pressure at two Pressure zones in a system. Model GP-200 indicates the resultant differential Pressure [DP] directly on a single Gauge dial. This can also be equipped with 'Switch Actuation' mechanism, as an important additional feature.

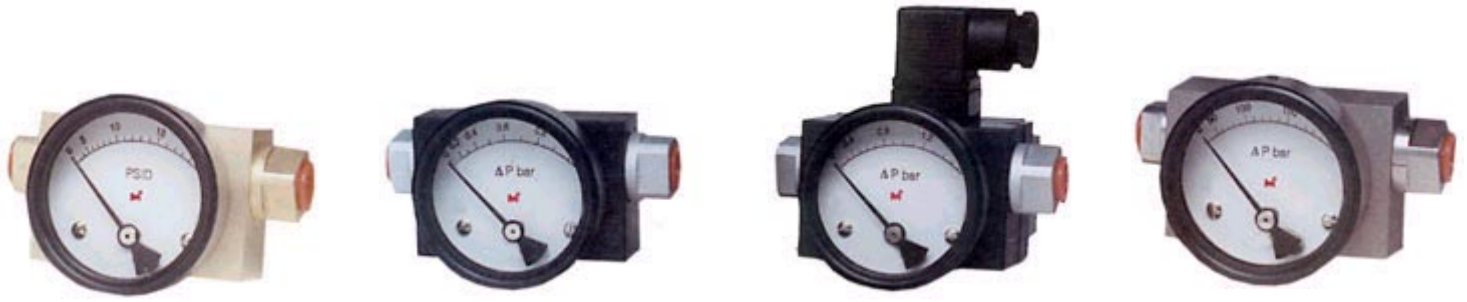

SPECIFICATIONS : **DIFFERENTIAL PRESSURE INDICATOR**

MODELS :

- GP - 200 : D.P. Indicator without switch
- GP - 201 : D.P. Indicator with single switch
- GP - 202 : D.P. Indicator with two switches
- DPS - 101 : D.P. switch with single switch
- DPS - 102 : D.P. switch with two switches

D.P. Ranges : 0 to ,0.5,1.0, 1.5, 2.0, 2.5, 3.0, 4.0, 5.0, 6.0, 7.0, 10...BAR

Max. Static Pressure : 25 bar ,200 bar , 450 bar or 700 bar

Accuracy : $\pm 2\%$ or 2.5% of FSR

End Seal : Static 'O' ring

Body Material & wetted Parts : Aluminium [standard]
: SS 316, BRASS [optional]

End connections : 1/4" BSP [std.]
: Others [specify]

Max. Process Temperature : + 80 °C [std]
: + 200 °C [optional]

Mounting : In-line [standard]
: Panel Mtg./Bottom Entry/ Back Entry [optional]

Finish : Powder coated [matt black] / Aluminium Anodised black

Housing : Weather proof IP-55 / IP-65

Casing [Front Bezel] : Aluminium [Std.] / SS-304/SS-316 [Optional]

Calibration : Ascending

Switch rating : 15 VA, 0.5A, 125 VAC/ 200 VDC

: 100 VA, 2.0 A, 230 VAC/ 300VDC

Switch type : Magnetic Reed Switch

No. of switches : 1 or 2 max. [optional]

Switching Differential : Fixed

GENERAL APPLICATIONS :

Across all types of filters, pipelines, pressurised non -

Pressurised tanks, vessels and chemical equipments.

Finds application in the following fields

- HYDRAULIC POWER PACK MANUFACTURERS
- FILTER MANUFACTURERS
- AIR COMPRESSOR MANUFACTURERS
- PHARMACEUTICAL INDUSTRIES
- C.N.C. MACHINES
- WATER TREATMENT PLANTS
- NUCLEAR, THERMAL AND HYDRAULIC POWER PLANTS
- TEXTILE MACHINERY
- AIR DRYER MANUFACTURERS etc.,

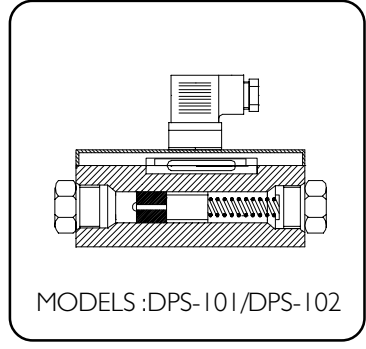

FILTER CLOG/D.P. SWITCHES

MODELS : DPS- 101/DPS 102.

The function of the filter Clog Indicator is to indicate the exact condition of filter element when it gets clogged. This instrument senses the differential pressure across the filter's 'High' & 'Low' connections on the filter line. Thus after some days, when the filter starts getting clogged due to dirt etc.the differential pressure across the filter builds up and indicates the clogging condition of the filter through Filter clog Indicator in a clockwise direction with the help of pointer. When it reaches to the full at extreme, it means the filter is fully clogged and needs replacement of filter element, thus acts as a continuous informer of the filter element condition and helps changing the filter element at optimum life performance !